

Dynamic Build Bed for Additive Manufacturing

Ismail Enes Yigit and Ismail Lazoglu

Manufacturing and Automation Research Center, Koc University,
Mechanical Engineering Department, Sariyer, Istanbul 34450, Turkey

Abstract

Compared to subtractive manufacturing, additive manufacturing generally has low material waste. However, models with large overhangs require manufacturing of support structures which ends up as waste material. This paper proposes the use of a dynamic build bed for reducing support structures. The bed consists of an array of actuated pins which move in the build orientation. Each pin can be individually moved to the correct height for supporting the given model. Two separate applications of the build bed are investigated. In the first application, the dynamic build bed is used as support structures in deposition-based AM methods. The pins individually raise out of the build bed to support the overhang geometry at the given deposition height. The second application is in powder-based AM methods. In the second application, the pins are used to fill the space of the powder where the geometry will not occupy. The pins are individually lowered in the build orientation to make space for a new powder layer. Thus, saving excessive deposition of powder.

Keywords: Support structures, Dynamic, Additive Manufacturing

1. Introduction

Additive manufacturing (AM) is praised to have low material waste in comparison to traditional manufacturing methods such as subtractive manufacturing. This is not valid for all given computer aided design (CAD) models. In deposition-based AM methods, the material needs to be deposited on an existing surface. When the given CAD model has overhangs, the material cannot be directly deposited. In this case the layer of the model needs to be supported by support structures. Support structures are manufactured just as the model itself only to support the overhang geometries. These support structures are not part of the final CAD geometry. Thus, they need to be manually removed after manufacturing and they end up as waste material. These support structures also increase the manufacturing and the require manual labor time.

In powder-based AM methods, the overhangs do not cause trouble since the powder is equally deposited to cover the whole layer at a time. This powder fills the space under the model and acts as a natural support structure for the whole geometry. Thus, any overhang of the model is also supported by the deposited powder. However, the powder degrades once after it has been through a manufacturing cycle and becomes waste. Therefore, it is beneficial to deposit the minimum amount of powder on each layer. This paper proposes the use of a dynamic build bed for reducing the manufacturing of support structures in the first application and reducing the deposition of powder material in the second application.

The bed consists of an array of actuated pins which move in the build orientation. Each pin can be individually moved to the required height for supporting the given model. The proposed dynamic bed system has been previously utilized in human computer interaction (HCI) field, but it has not been utilized in AM. Sean Follmer and Daniel Leithinger have introduced the

inFORM system which is a 2.5D shape display consisting of 30x30 array of linearly actuated pins [1] given in Figure 1. Each pin can dynamically move in the Z orientation for interaction with the user or manipulation of the physical objects on the display. A single pin can exert 1 Newton of force and extend up to 100mm from the surface. The height map of the pins is calculated by OpenGL shaders and are sent to the 900 pins via a microcontroller.

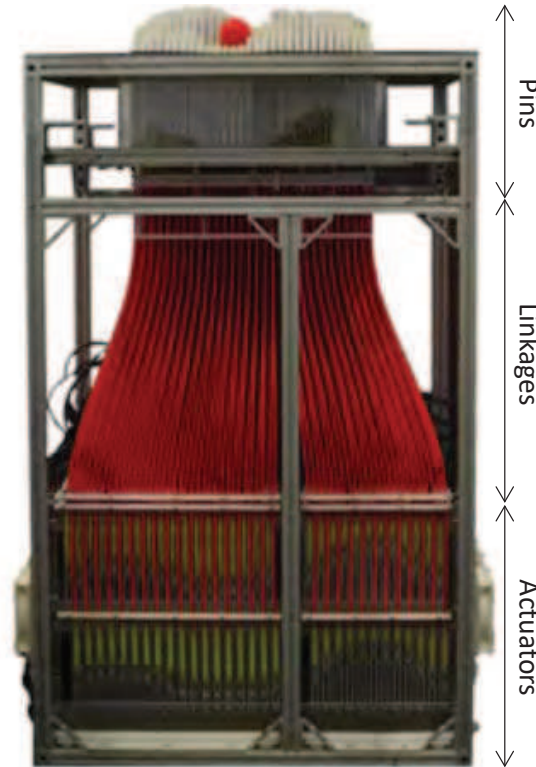

Figure 1: The inFORM system with 900 mechanical actuators connected to the pins with the linkages [1]

Leithnerger et. al later used the inFORM shape display to physically render shapes and geometries [2]. They also proposed that users can use these shape displays to quickly render physical CAD models before they are additively manufactured. Rendering before AM will improve the prototyping cycles. In this paper, it is proposed to use the given physical renders as support structures in the AM process.

Several work in the literature proposes methods to reduce support materials. Some of these works are focused on multidirectional manufacturing where the deposition tool has more than three degrees of motion and can deposit in non-conventional orientations [3]. Another method is placement of foreign object as support structures in convenient locations where the deposition head can continue deposition without collision [4]. Support structure optimizations are applied such as the sloping wall support structures [5] where the total volume of the support structure is reduced by reducing the cross sectional area of the support with the minimum self-supporting angle. Another method is support slimming to optimize the geometry by changing its shape to be more self-supported [6]. Optimization of the build orientation of the model [7, 8] is also an effective approach where the original model can be manufactured on the conventional supports at an orientation requiring the minimum amount of support.

The proposed method in this paper has been practiced by the flexible support structures [9]. In this paper a flexible platform consisting of actuated basic units used. The paper includes a control module for support structure reduction and automatic unloading. Support structure reduction mainly includes 3 steps. The first step is to discretize the model's printing space to pieces. The second step is to identify the lowest point of each piece. The third step is to offset the base of support structure. This paper adds to the flexible support structure by introducing a universal algorithm valid for both deposition-based AM systems and for powder-based AM systems.

This paper starts with introducing the conventional support structures from the literature in section 2. Then in section 3, dynamic support structures are introduced. Two separate applications of the build bed are investigated in the following sections. The first application given in section 4 is the dynamic build bed in deposition-based AM methods. In this application, the pins individually raise out of the build bed to support the overhang geometries at the given deposition height. The second application, given in section 5, is the use of dynamic build bed in powder-based AM. In this application, the pins are used to fill the space of the powder where the geometry will not occupy. The pins are individually lowered in the build orientation to make space for a new powder layer. The paper ends by giving the conclusion.

2. Conventional supports

AM is a process where the given CAD model is manufactured layer by layer. The CAD model is usually given as a Stereolithography (STL) file [10]. This file consists of a triangulated mesh of the model. To find the overhang geometries which require support structures, the minimum self-supporting angle θ of each triangular mesh is calculated using the cosine law given in equation (1). In this equation \vec{N} represents the normal of the mesh and the \hat{k} represents the build orientation. The minimum self-supporting angle generally ranges from 30 to 60 degrees which changes with different AM methods.

$$\theta = \cos^{-1} \frac{\vec{N} \cdot -\hat{k}}{\|\vec{N}\| \|\hat{k}\|} \quad (1)$$

The meshes which do not meet the minimum self-supporting angle criteria gives the regions of the model which require support structures. These regions are then sampled in the two-dimensional plane parallel to the build bed. The sampled points give the support points. The sampling quality depends on the spacing of the support structures. For each support point a ray is cast towards the build bed [11]. If the ray hits the model, the support structure starts on the model. If the ray reaches the build bed the support structure starts from the build bed and is eligible to be replaced by the pins of the dynamic build bed. Dynamic support structures are studied in the next section.

3. Dynamic support structures

The dynamic support structures consist of a two-dimensional array of pins as introduced in section 1. Each pin can move independently in the build orientation. The geometry of the pins is identical and is in the shape of a square prism with user set width w and height h as shown in Figure 1. In this figure, total of 361 pins are shown where some of them are raised for illustration. The number of pins can be set depending on the required build bed dimensions. The width and height of the pins together with the number of pins give the pin configuration.

The proposed method in this paper calculates the dynamic support structures for any CAD model with any given pin configuration.

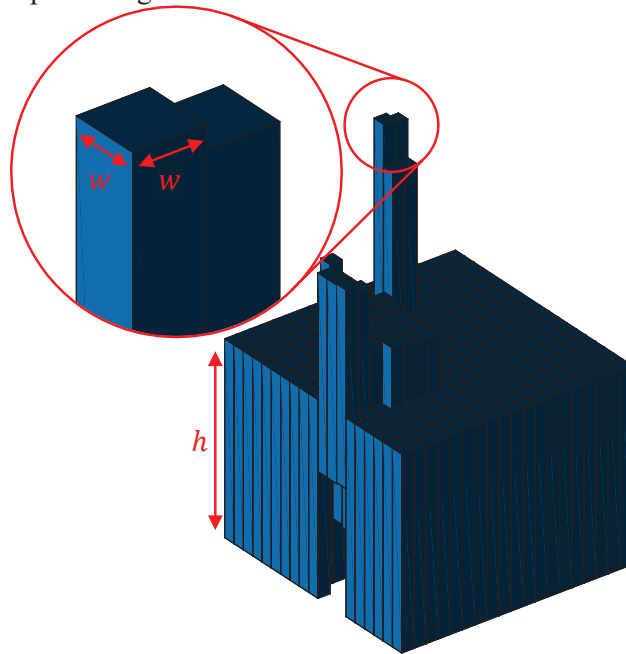

Figure 2: Dynamic build bed of 361 pins with width w of 10[mm] and height h of 150[mm]

After the pin configuration is set, the next step is to find the support points as introduced in section 2. As the width of the pins gets coarser, the pins tend to collide with the manufactured model. To deal with this, a ray is cast from each corner of the pin. Then collision is checked in the same way which the support points were checked. The results are as shown in Figure 3. In this figure the points where the ray hits the model are given in red. The points of the model which require support are highlighted in green. Any highlighted point which is reachable by with without colliding with the model is reached by a pin. Here the whole model shown where the pins are at their final positions. During the AM process, the pins will raise in increments of the layer height. After each layer is deposited, the pins will raise as much as the layer height to support the new layer. When a pin reaches its final height, it will be fixed at that position until the process is reset. The pins can also move individually in a wave motion to release the from the build bed for easy removal.

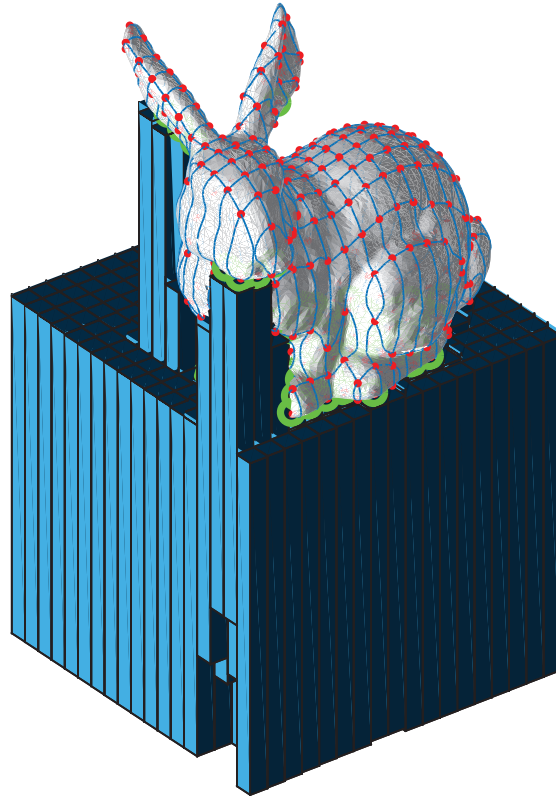

Figure 3: Support points of the Stanford Bunny

As introduced previously, the dynamic build bed can be used in two different applications. The figures up to this point have all illustrated the application for deposition-based AM where the pins are raised out of the build bed. The next section will investigate the use of the dynamic build bed in deposition-based AM.

4. Dynamic build bed in deposition-based AM

The first application of the dynamic build bed is the usage of the pins as support structures in deposition-based AM methods. The pins individually raise out of the build bed to support the overhang geometry at the given deposition height. At this point the pins will move either upwards or downwards depending on the AM method. Simulations have been conducted for both applications with two different models to verify the proposed dynamic build bed method. **Figure 4** and **Figure 5** illustrate the results for deposition-based AM.

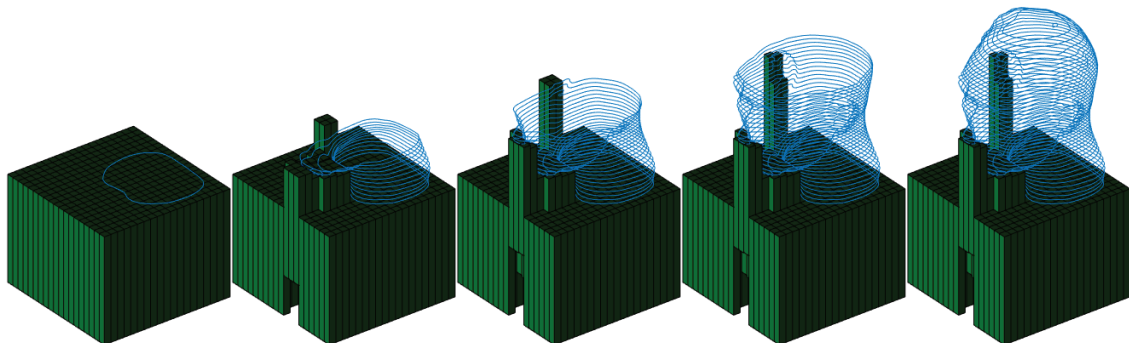

Figure 4: Dynamic build bed in deposition-based AM with Ataturk Model

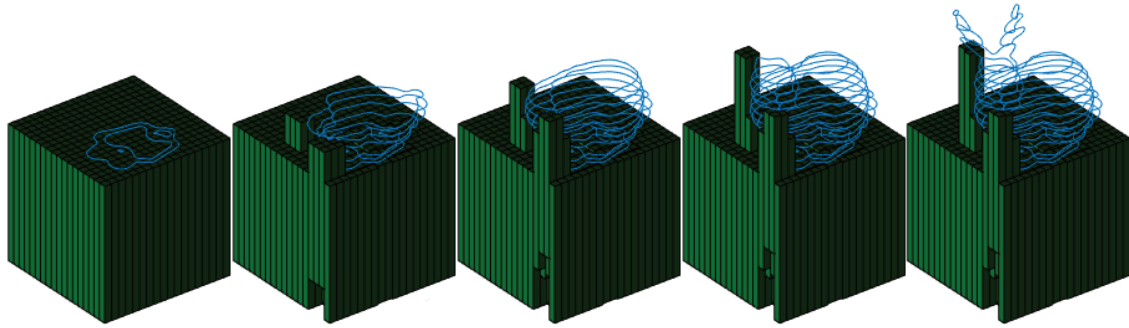

Figure 5: Dynamic build bed in deposition-based AM with Bunny Model

The corner with the lowest collision height is taken as the maximum height which the pin can raise. After the maximum height is calculated for each pin, these values are stored on a two-dimensional matrix. When the manufacturing has started, each pin is raised as much as the layer height when the extruder moves to the next layer. At each step, the maximum height of the pin is checked. If the pin has reached its maximum value, it is fixed at that position. This means that the pin is ready to support the model and should not move anymore.

5. Dynamic build bed in powder-based AM

The second application is in powder-based AM methods. In powder-based methods, there is no need for special support structures as the powder itself acts as a natural support structure. In the case that most of the build box is empty, the powder that is laid to fill up the layer will go through a heat cycle and deteriorate over time. Since the powder is usually an expensive resource, it is in our best interest to lay the least amounts of powder. Here the pins are used to fill the space of the powder where the geometry will not occupy. The pins are individually lowered in the build orientation to make space for a new powder layer. Thus, excessive deposition of powder is prevented. **Figure 6** and **Figure 7** illustrate the results for powder-based AM

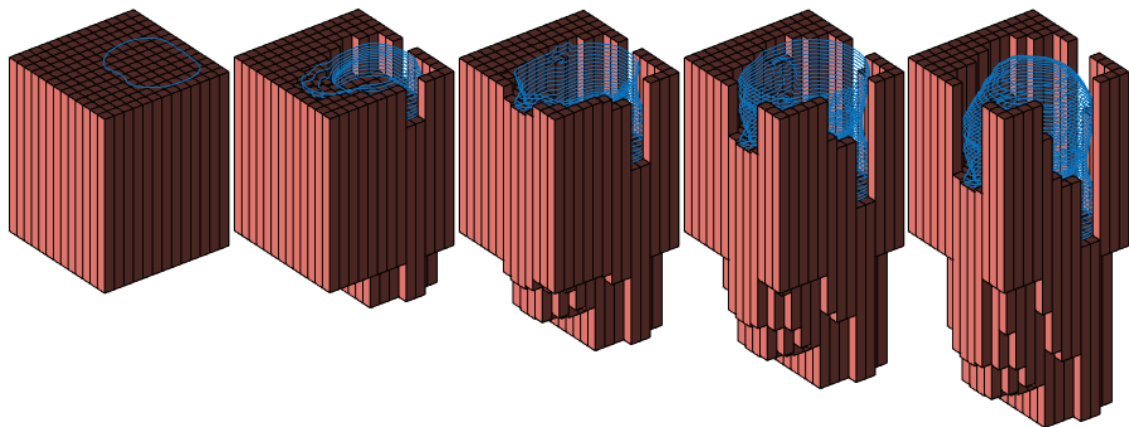

Figure 6: Dynamic build bed in powder-based AM Ataturk Model

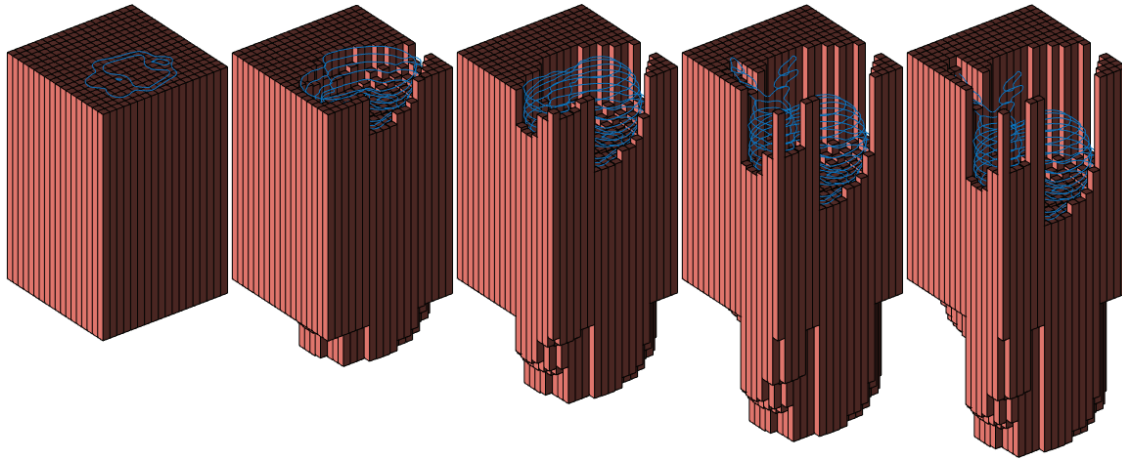

Figure 7: Dynamic build bed in powder-based AM with Bunny Model

The manuscript is ended with the conclusion.

6. Conclusion

Dynamic build bed for reducing the use of support structures and powder has been introduced. An array of actuated pins which move in the build orientation assist the AM process. Every pin is individually actuated to reach the desired position under the CAD model. Two separate implementations are given in this paper. The first implementation is for deposition based AM where the dynamic build bed is used for support structures. Each pin raises to support the overhang geometry at the required height. The second implementation is in for powder-based AM where the pins fill the space where the powder originally occupies. Each pin is lowered in the build orientation to make space for the model's new layer. This results in less usage of powder. To verify the improvement of the proposed implementations, two models are simulated, and the results are compared to the conventional methods. Minimizing the fabrication of support structures, the material waste can be reduced, which also results in a reduction in fabrication time. Future work includes testing the proposed method on a mechanical setup.

7. Acknowledgements

This research was supported by the Koç University Manufacturing and Research Center.

8. References

1. Follmer S, Leithinger D, Olwal A, et al (2013) inFORM: Dynamic Physical Affordances and Constraints through Shape and Object Actuation. Proc 26th Annu ACM Symp User interface Softw Technol - UIST '13 417–426 . doi: 10.1145/2501988.2502032
2. Leithinger D, Follmer S, Olwal A, Ishii H (2015) Shape Displays: Spatial Interaction with Dynamic Physical Form. IEEE Comput Graph Appl 35:5–11 . doi: 10.1109/MCG.2015.111
3. Ruan J, Eiamsa-ard K, Liou FW (2005) Automatic Multi-Axis Slicing Based on Centroidal Axis Computation. Vol 3 25th Comput Inf Eng Conf Parts A B 2005:383–393 . doi: 10.1115/DETC2005-85261
4. Yigit IE, Isa M, Lazoglu I (2018) Additive Manufacturing with Modular Support

- Structures. In: Solid Freeform Fabrication 2018: Proceedings of the 29th Annual International Solid Freeform Fabrication Symposium – An Additive Manufacturing Conference. pp 2142–2150
5. Huang X, Ye C, Wu S, et al (2009) Sloping wall structure support generation for fused deposition modeling. *Int J Adv Manuf Technol* 42:1074–1081 . doi: 10.1007/s00170-008-1675-2
 6. Hu K, Jin S, Wang CCL (2015) Support slimming for single material based additive manufacturing. *CAD Comput Aided Des* 65:1–10 . doi: 10.1016/j.cad.2015.03.001
 7. Strano G, Hao L, Everson RM, Evans KE (2013) A new approach to the design and optimisation of support structures in additive manufacturing. *Int J Adv Manuf Technol* 66:1247–1254 . doi: 10.1007/s00170-012-4403-x
 8. Hur J, Lee K (1998) The development of a CAD environment to determine the preferred build-up direction for layered manufacturing. *Int J Adv Manuf Technol* 14:247–254 . doi: 10.1007/BF01199879
 9. Hongyao S, Xiaoxiang Y, Jianzhong F (2018) Research on the flexible support platform for fused deposition modeling. *Int J Adv Manuf Technol* 97:3205–3221 . doi: 10.1007/s00170-018-2046-2
 10. Bianconi F (2002) Bridging the gap between CAD and CAE using STL files. *Int. J. CAD/CAM* 2:55–67
 11. Möller T, Trumbore B (1997) Fast, Minimum Storage Ray-Triangle Intersection. *J Graph Tools* 2:21–28 . doi: 10.1080/10867651.1997.10487468